

6710

counter space POS

efficiency

NCI Model 6710 is designed for use in cafeterias, convenience stores, delicatessens, restaurants, candy shops or anywhere space is a premium.

- ◆ **Low Profile** Only 2.5" high.
- ◆ **Small Footprint** 10" x 10" platter.
- ◆ **Easy to Read** Six-digit LCD external display with large 0.5" characters, tactile keys, 7 ft. cable and Velcro™ for mounting.
- ◆ **Accurate and Reliable** Precision load cell and quality electronics ensure repeatable weight measurements and trouble-free operation.
- ◆ **Simple to Use** Reduces operator training time.
- ◆ **Easy to Install** Interfaces to most electronic cash registers and point-of-sale software programs.
- ◆ **Interfaces** RS-232, 4-bit parallel, 40-bit serial, and OPOS.
- ◆ **Auto Zero Tracking** Zero light indicator and manual control when out of range.
- ◆ **Quick Disconnects** Make all cable connections easily.
- ◆ **Construction** Stainless steel weighing area with full skirt around perimeter of base, except where connectors are located at rear of scale.

shown with optional display bracket.



Standard point-of-sale interface scale for linking to electronic cash registers or POS systems.

shown with optional remote display post.



Avery Berkel

counter space POS efficiency

OPTIONS

- ◆ **Display Post** 12" high post for attachment to remote display.
- ◆ **Display Brackets** Attach remote display to scale base.
- ◆ **International Power Supply** 230 VAC, 50 Hz power supply. Cable terminated with a universal connector.
- ◆ **Cables** Interface cables available for PCs and specific ECRs.

SPECIFICATIONS

- ◆ **Capacity and Resolution**

Pounds	Kilograms
15 x 0.005	7 x 0.002
30 x 0.01	15 x 0.005
- ◆ **Dimensions**

Weigh Platter: 10" x 10" (254 mm x 254 mm)
Remote Display Enclosure: 5.8" W x 3.0" H x 1.4" D max (147 mm x 76 mm x 35 mm)
Adjustable Height: 2.5" – 3.0" (63 mm – 76 mm)
- ◆ **Power**

Input: Wall mount transformer 120 VAC (+10% -15%)/ 60 Hz (±3 Hz)
Standard 3 wire with ground input
Output: 15 VDC @ 0.3 Amps minimum
- ◆ **Operating Environment**

41°F to 104°F (5°C to 40°C) (Class III device)
10% to 90% RH (non-condensing)
- ◆ **Agency Approvals**

Legal for Trade, NTEP Class III, USA COC #95-070A6
Canada: MOI approval #AM-5076 Rev. 2
Power Supply: UL Listed, CSA Certified



DIMENSIONS

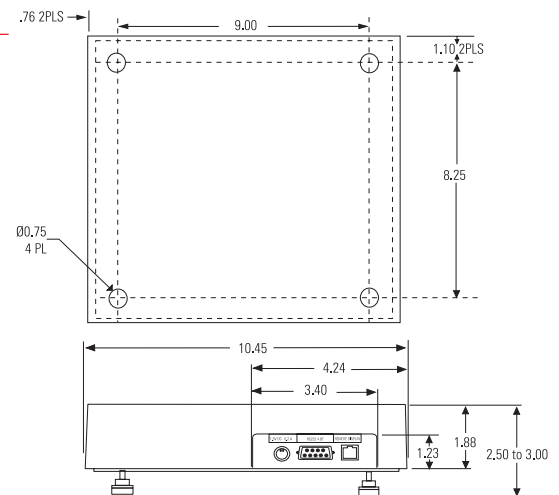

© Avery Weigh-Tronix 2003. All rights reserved. This publication is issued to provide outline information only which, unless agreed by Avery Weigh-Tronix in writing, may not be regarded as a representation relating to the products or services concerned. Avery Weigh-Tronix reserves the right to alter without notice the specification, design, price or conditions of supply of any product or service.



As we continually strive to improve our products, specifications are necessarily subject to change without notice. Product complies with F.C.C..

Avery Weigh-Tronix
(Retail North America)

1758 Genesis Drive, Suite A
LaPorte, IN 46350

PH Toll-Free: 800-237-1886

PH: 219-325-9587

FAX Toll-Free: 800-237-2063

FAX: 219-325-9594

E-mail: sales@AveryBerkelUSA.com
Internet: <http://www.AveryBerkelUSA.com>

Avery Weigh-Tronix